



2023-'24 S&S[®] Cycle, Inc.

All rights reserved.
Printed in the U.S.A.

Installation Instructions: S&S Performance Replacement Crankcase for M8 Touring Models (part numbers 310-1170, 310-1313)

DISCLAIMER:

S&S parts are designed for high performance, closed course, racing applications and are intended for the very experienced rider only. The installation of S&S parts may void or adversely affect your factory warranty. In addition such installation and use may violate certain federal, state, and local laws, rules and ordinances as well as other laws when used on motor vehicles used on public highways, especially in states where pollution laws may apply. Always check federal, state, and local laws before modifying your motorcycle. It is the sole and exclusive responsibility of the user to determine the suitability of the product for his or her use, and the user shall assume all legal, personal injury risk and liability and all other obligations, duties, and risks associated therewith.

The words Harley[®], Harley-Davidson[®], H-D[®], Sportster[®], Evolution[®], and all H-D part numbers and model designations are used in reference only. S&S Cycle is not associated with Harley-Davidson, Inc.

Exempt from emissions tampering regulations under CARB EO# D-355-49 for all 2017 -2024 touring models

SAFE INSTALLATION AND OPERATION RULES:

Before installing your new S&S part it is your responsibility to read and follow the installation and maintenance procedures in these instructions and follow the basic rules below for your personal safety.

- Gasoline is extremely flammable and explosive under certain conditions and toxic when breathed. Do not smoke. Perform installation in a well ventilated area away from open flames or sparks.
- If motorcycle has been running, wait until engine and exhaust pipes have cooled down to avoid getting burned before performing any installation steps.
- Before performing any installation steps disconnect battery to eliminate potential sparks and inadvertent engagement of starter while working on electrical components.
- Read instructions thoroughly and carefully so all procedures are completely understood before performing any installation steps. Contact S&S with any questions you may have if any steps are unclear or any abnormalities occur during installation or operation of motorcycle with a S&S part on it.
- Consult an appropriate service manual for your motorcycle for correct disassembly and reassembly procedures for any parts that need to be removed to facilitate installation.
- Use good judgment when performing installation and operating motorcycle. Good judgment begins with a clear head. Don't let alcohol, drugs or fatigue impair your judgment. Start installation when you are fresh.
- Be sure all federal, state and local laws are obeyed with the installation.
- For optimum performance and safety and to minimize potential damage to carb or other components, use all mounting hardware that is provided and follow all installation instructions.
- Motorcycle exhaust fumes are toxic and poisonous and must not be breathed. Run motorcycle in a well ventilated area where fumes can dissipate.

IMPORTANT NOTICE:

Statements in this instruction sheet preceded by the following words are of special significance.



WARNING

Means there is the possibility of injury to yourself or others.



CAUTION

Means there is the possibility of damage to the part or motorcycle.

NOTE

Other information of particular importance has been placed in italic type.

S&S recommends you take special notice of these items.

WARRANTY:

All S&S parts are guaranteed to the original purchaser to be free of manufacturing defects in materials and workmanship for a period of twelve (12) months from the date of purchase. Merchandise that fails to conform to these conditions will be repaired or replaced at S&S's option if the parts are returned to us by the purchaser within the 12 month warranty period or within 10 days thereafter.

In the event warranty service is required, the original purchaser must call or write S&S immediately with the problem. Some problems can be rectified by a telephone call and need no further course of action.

A part that is suspect of being defective must not be replaced by a Dealer without prior authorization from S&S. If it is deemed necessary for S&S to make an evaluation to determine whether the part was defective, a return authorization number must be obtained from S&S. The parts must be packaged properly so as to not cause further damage and be returned prepaid to S&S with a copy of the original invoice of purchase and a detailed letter outlining the nature of the problem, how the part was used and the circumstances at the time of failure. If after an evaluation has been made by S&S and the part was found to be defective, repair, replacement or refund will be granted.

ADDITIONAL WARRANTY PROVISIONS:

- (1) S&S shall have no obligation in the event an S&S part is modified by any other person or organization.
- (2) S&S shall have no obligation if an S&S part becomes defective in whole or in part as a result of improper installation, improper maintenance, improper use, abnormal operation, or any other misuse or mistreatment of the S&S part.
- (3) S&S shall not be liable for any consequential or incidental damages resulting from the failure of an S&S part, the breach of any warranties, the failure to deliver, delay in delivery, delivery in non-conforming condition, or for any other breach of contract or duty between S&S and a customer.
- (4) S&S parts are designed exclusively for use in Harley-Davidson[®] and other American v-twin motorcycles. S&S shall have no warranty or liability obligation if an S&S part is used in any other application.

Please read these instructions thoroughly before starting work. Proceed with the installation only after they are completely understood. These instructions should be supplemented by the appropriate OEM service manual for your motorcycle. Follow all safety information.

Introduction

S&S M-series crankcase assembly is a direct replacement for M8 Touring models.

Note: S&S crankcases are sold in matched sets only. Individual case halves are not available.

The customer must verify that the serial numbers on the crankcase and attached information tag correspond to those on the packing carton. Note: A valid Manufacturers Statement of Origin (MSO) document is required for any transfer or sale of aftermarket crankcases or complete engines built with aftermarket crankcases. Certificate of origin documentation is required to title and license any motorcycle which is to be driven on public streets and highways.

Additional Features:

- Greater overall strength as compared to the stock crankcases, especially in the motor mount and stator location. Additional reinforcement webbing in critical areas and increased cross sectional area throughout the casting all add up to a stronger crankcase.
- Additional surface area on the case mating surfaces.
- All oil passages between the cam support plate and crankcase are o-ring sealed
- Compatible with stock components. Oil pump, cam support plate, flywheel assembly, balancer assembly, stator, cam cover, etc.
- S&S crankcase assemblies are supplied with main bearings, balancer bearings, inner cam bearings, cylinder studs, piston oilers, o-rings and hardware.

Modifications

S&S Cycle cautions against modifying these crankcases due to the possibility of damaging or weakening them. Modifying S&S crankcases in any fashion voids all manufacturer warranties.

Under no circumstance will S&S be held responsible for expenses related to the modification of any S&S part in the event warranty service is required. Modified parts will not be accepted for credit or exchange. For further information, contact S&S Technical Services at 608-627-8324 or email sstech@sscycle.com

Subjecting heat-treated alloys such as those used in S&S crankcases to excessive heat can drastically alter their strength. The degree of change depends upon the temperatures reached and the duration of exposures. When powder coating or otherwise processing alloy parts, S&S exposes them to a maximum temperature of 370 deg F for no longer than 20 minutes. Under no circumstances should parts be heated past 400° F.

Kit Contents

Crankcase Assembly

<i>Item</i>	<i>Qty</i>
Main Bearings.....	2
Balancer Shaft Bearings.....	2
Inner Cam Bearing.....	1
Cylinder Studs.....	8
Magnetic Drain Plug.....	1
¼" Pipe Plugs.....	4
CARB EO Label.....	1

Hardware Kit-Fasteners

5/16" Hex Head Cap Screws and washers.....	9
¼" Hex Head Cap Screw with washers and nut.....	1
The crankcase is held together with 2 5/16" cap screws and washers. These fasteners are to be reused for final assembly.	

Hardware Kit-O-rings

-013 o-ring .437" ID x .565" OD.....	4
-014 o-ring .500" ID x .625" OD.....	1
-116 o-ring .737" ID x .942" OD.....	1
-209 o-ring .687" ID x .937" OD.....	1

Piston Cooling Jet Kit

Front Piston Cooling Jet.....	1
Rear Piston Cooling Jet.....	1
Piston Cooling Jet Gaskets.....	2
8-32 x 3/4" Torx head screws.....	4

Hardware Kit Miscellaneous

Bearing Retainer Plate.....	1
8-32 x 5/16" Flat Head Screw.....	3
Flywheel Thrust Washer.....	1
Output Shaft Seal.....	1
5/16-18 Stud.....	1
¼"x¾" Socket Head Cap Screw w/Washer (for Crank Position Sensor).....	1

Preparation

1. Inspection

- Inspect crankcases to confirm that they are correct for your application.
- Verify that serial numbers on crankcases match numbers on packing carton and certificate of origin. Contact S&S immediately if numbers do not match.

2. Crankcase test fit

If possible, the bare crankcase should be positioned in the motorcycle frame before assembly to check clearances.

- Position case in frame, check the clearance at frame and alignment to transmission. It is a good idea to replace rubber engine and transmission mounts at this time. Old mounts deform over time and may induce unwanted stresses on the engine case.

Note: Crankcase damage to improper installation is not covered under warranty

3. Pre-Assembly Cleaning

- Clean crankcases in hot soapy water or solvent to remove any dirt or contamination which may be introduced during shipping, handling or setup. Dry components and clear passages with compressed air. It is not necessary to remove the installed pipe plugs. All S&S cases go through a thorough deburring and cleaning process before assembly.

Warning: Compressed air and particles dislodged by compressed air are potentially harmful. Wear protective goggles when using compressed air and always direct air stream away from yourself and others.

Assembly

4. Piston Cooling Jet Assembly.

- Locate the piston cooling jets, gaskets and 4-Torx head screws.
- Check for raised material around the threaded holes. Each hole is chamfered before leaving the S&S facility.
- Apply a small amount of low-strength blue threadlocker to the provided fasteners.
- Place the gasket and cooling jet in the appropriate location (the cooling jets are marked "F" and "R" and cannot be installed in the wrong locations).
- Install the screws and torque evenly to 30 in-lbs

5. Bearing Retainer Plate

The bearing retainer plate is installed in the cam chest adjacent to the right side main bearing. With the bearing retainer plate installed, the seal (if equipped) on the back side of the oil pump (S&S, OEM, or other aftermarket) must be removed. The bearing retainer plate and oil pump seal cannot be installed together. It is the engine builder's decision to use either the bearing retainer plate or the seal on the backside of the oil pump.

- Locate the bearing retainer plate and 3-Flat head, phillips drive screws
- Check for raised material around the threaded holes.
- Apply a small amount of low-strength blue threadlocker to the provided fasteners (8-32 flathead screws qty 3.)
- Install the screws and torque evenly to 30 in-lbs

6. Cylinder Studs

Cylinder studs have been installed with red-threadlocker and torqued to 25 ft*lbs.

7. Flywheel Assembly

S&S M-Series crankcases are compatible with stock or S&S flywheel assemblies. A flywheel thrust washer and output shaft seal have been provided.

IMPORTANT
Install the flywheel thrust washer before the output shaft oil seal is installed.

Crankcase Fasteners	Initial Torque	Final Torque
5/16"	120 in*lbs	20 ft*lbs
1/4"	60 in*lbs	120 in*lbs

- Place the cam side crankcase on a suitable work surface with the cam chest facing down (crankcase split line surface up). It will be necessary to put prop up the crankcase slightly to allow the pinion shaft to protrude past the cam cover mouting surface.
- Install the flywheel assembly into the crankcase.
- Apply a quality sealer on the mating flange on the cam side of the crankcase assembly. S&S highly recommends Permatex Right Stuff gasket maker or Threebond Liquid Gasket 1194.
- Install the balancer shaft with the "-" marks aligned. Make sure the flywheel and balancers rotate freely.

The crankcase fasteners should be tightened in a two step process. Follow the tightening pattern indicated in the following picture.

Step 1:

- Tighten fastener #1 to 60 in*lbs
Tighten fasteners #2 thru #12, in sequence, to 120 in*lbs

Step 2:

- Tighten fasteners #2 thru #12, in sequence, to 20 ft*lbs
Tighten fastener #1 to 120 in*lbs

Crankcase bolt torque pattern

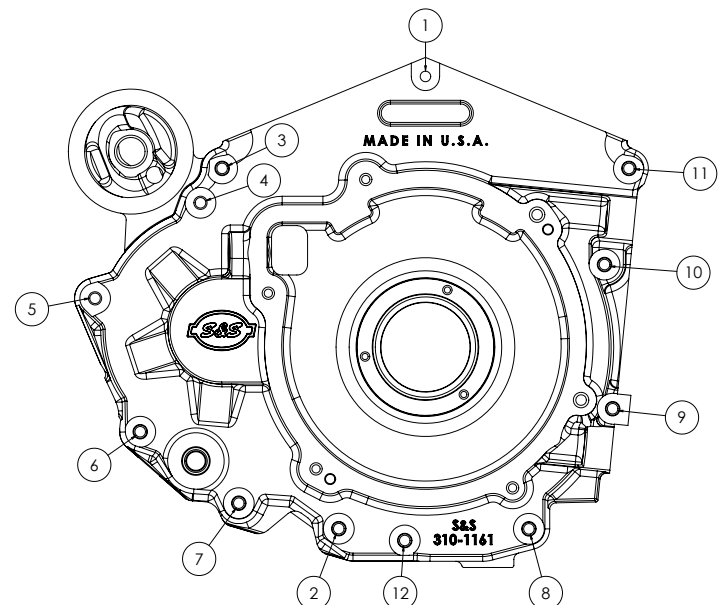

8. Crank Position Sensor

- A 3/4" long, socket head cap screw with washer has been provided in the hardware kit.
- Apply a small amount of low-strength blue threadlocker to the provided fastener.
- Torque to 80-90 in*lbs

9. Camchest Components

See the following picture for o-ring locations. Apply oil or assembly lube to the o-rings to keep them in place during assembly. Install the camshaft, oil pump, cam support plate, tappets and tappet cuffs according to the manufacturer's instructions.

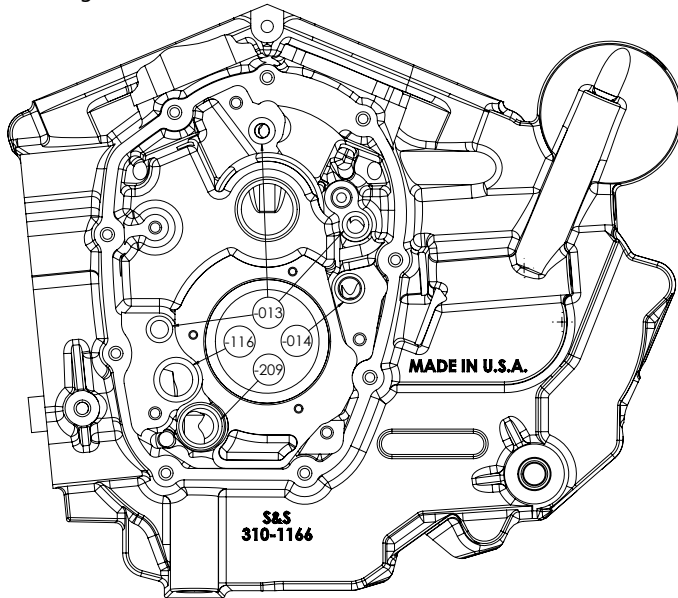

10. Stator Assembly

- Apply glass cleaner or isopropyl alcohol to the grommet on the stator wires.
- Feed the wires thru the hold in the engine case and seat the grommet.
- Use new (not provided) screws for the stator and torque 55-75 in*lbs.

11. Primary Chaincase Housing

Follow the installation instructions outlined in the factory service manual.

12. CARB EO Label

Apply the included label containing the CARB EO number to the left front frame down tube above or below the factory labeling. Do not cover up any portion of the factory label.



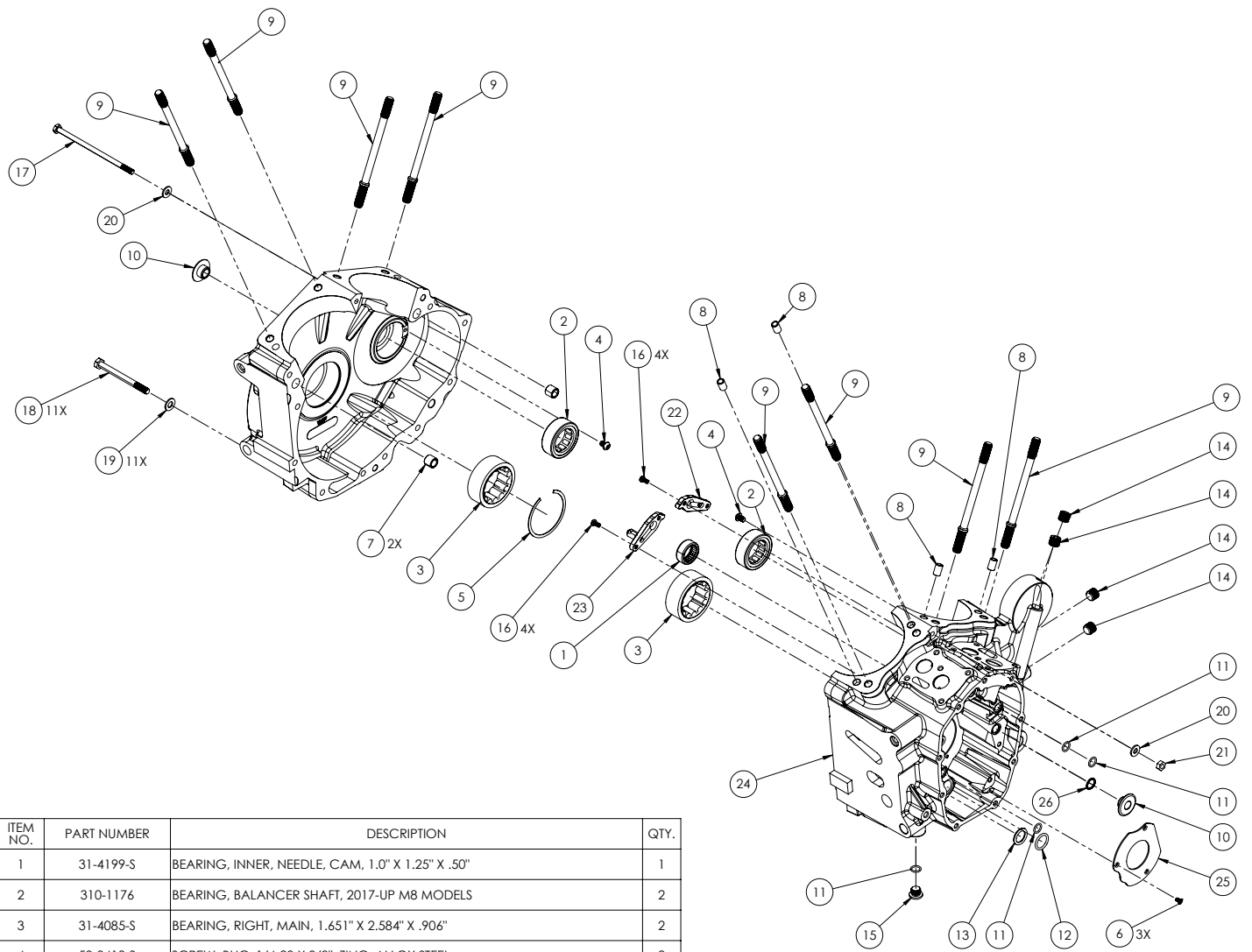

ITEM NO.	PART NUMBER	DESCRIPTION	QTY.
1	31-4199-S	BEARING, INNER, NEEDLE, CAM, 1.0" X 1.25" X .50"	1
2	310-1176	BEARING, BALANCER SHAFT, 2017-UP M8 MODELS	2
3	31-4085-S	BEARING, RIGHT, MAIN, 1.651" X 2.584" X .906"	2
4	50-0413-S	SCREW, BHC, 1/4-20 X 3/8", ZINC, ALLOY STEEL	2
5	50-8160-S	RETAINING RING, INTERNAL, 2.731" X .031" X .158", STEEL, SAE 1070-1090	1
6	500-1750	SCREW, 8-32X5/16", FLAT HEAD, UNDERCUT, STAINLESS STEEL	3
7	50-8023	PIN, DOWEL, .557" X .500", BLACK, STEEL	2
8	500-0275	PIN, DOWEL, HOLLOW, .374" X .575", STEEL	4
9	310-1172	STUD, CYLINDER BASE, 7/16-14 UNC X 6.250", BLACK, STEEL	8
10	310-1173	SPACER, FRONT, MOUNT, CRANKCASE, 2017-UP M8 MODELS	2
11	50-8008	O-RING, (-013), .437" ID X .565" OD, VITON®	4
12	50-7954-S	O-RING, (-116), .737" ID X .942" OD, VITON®	1
13	50-8039	O-RING, (-209), .687" ID X .937" OD, VITON®	1
14	50-8330A	PLUG, PIPE, W/YELLOW PATCH, 3/4 TAPER, 1/4-18 NPTF X 7/16", ZINC, STEEL	4
15	50-8335-S	PLUG, DRAIN, MAGNETIC, 1/2-20, ZINC, STEEL	1
16	50-0054-S	SCREW, TORX PANHEAD, TRI-LOBE, 8-32 X 3/8", ZINC, STEEL	4
17	50-0090	SCREW, HHC, GR8, 1/4-28 X 5-1/2", ZINC, STEEL	1
18	50-0117	SCREW, HHC, GR8, 5/16-18 X 3-1/2", ZINC, STEEL	11
19	50-7034	WASHER, FLAT, .344" X .688" X .065", ZINC, STEEL	11
20	50-7021	WASHER, FLAT, .281" X .625" X .080", ZINC, STEEL	2
21	50-5011	NUT, HH, 1/4-28 UNC-2B X .226", ZINC, STEEL	1
22	310-1200	JET, ASSEMBLY, FRONT, PISTON COOLING, M-SERIES	1
23	310-1201	JET, ASSEMBLY, REAR, PISTON COOLING, M-SERIES	1
24	NA	CRANKCASE, LEFT, RIGHT, STOCK BORE, STOCK BOLT PATTERN, STOCK DRIVE BEARING, MACHINED, WBLACK, 2017-UP M-SERIES TOURING	1
25	330-0763	PLATE, BEARING RETENTION, PINION SHAFT, M SERIES	1
26	50-8270	O-RING, (-014), .500" ID X .625" OD, BROWN, VITON®	1