



Installation Instructions: Mid Mount Brake Pedal Kit for M8 Softail® Models

DISCLAIMER:

Many S&S parts are designed for high performance, closed course, racing applications and are intended for the very experienced rider only. The installation of S&S parts may void or adversely affect your factory warranty. In addition such installation and use may violate certain federal, state, and local laws, rules and ordinances as well as other laws when used on motor vehicles used on public highways. Always check federal, state, and local laws before modifying your motorcycle. It is the sole and exclusive responsibility of the user to determine the suitability of the product for his or her use, and the user shall assume all legal, personal injury risk and liability and all other obligations, duties, and risks associated therewith.

The words Harley®, Harley-Davidson®, H-D®, HD®, Sportster®, Evolution®, and all H-D part numbers and model designations are used in reference only. S&S Cycle is not associated with Harley-Davidson, Inc.

SAFE INSTALLATION AND OPERATION RULES:

Before installing your new S&S part, it is your responsibility to read and follow the installation and maintenance procedures in these instructions and follow the basic rules below for your personal safety.

- Gasoline is extremely flammable and explosive under certain conditions and toxic when breathed. Do not smoke. Perform installation in a well ventilated area away from open flames or sparks.
- If motorcycle has been running, wait until engine and exhaust pipes have cooled down to avoid getting burned before performing any installation steps.
- Before performing any installation steps, disconnect battery to eliminate potential sparks and inadvertent engagement of starter while working on electrical components.
- Read instructions thoroughly and carefully so all procedures are completely understood before performing any installation steps. Contact S&S with any questions you may have if any steps are unclear or any abnormalities occur during installation or operation of motorcycle with an S&S part on it.
- Consult an appropriate service manual for your motorcycle for correct disassembly and reassembly procedures for any parts that need to be removed to facilitate installation.
- Use good judgment when performing installation and operating motorcycle. Good judgment begins with a clear head. Don't let alcohol, drugs or fatigue impair your judgment. Start installation when you are fresh.
- Be sure all federal, state and local laws are obeyed with the installation.
- For optimum performance and safety and to minimize potential damage to carb or other components, use all mounting hardware that is provided and follow all installation instructions.
- Motorcycle exhaust fumes are toxic and poisonous and must not be breathed. Run motorcycle in a well ventilated area where fumes can dissipate.

IMPORTANT NOTICE:

Statements in this instruction sheet preceded by the following words are of special significance.



WARNING

Means there is the possibility of injury to yourself or others.



CAUTION

Means there is the possibility of damage to the part or motorcycle.

NOTE

Other information of particular importance has been placed in italic type.

S&S recommends you take special notice of these items.

WARRANTY:

All S&S parts are guaranteed to the original purchaser to be free of manufacturing defects in materials and workmanship for a period of twelve (12) months from the date of purchase. Merchandise that fails to conform to these conditions will be repaired or replaced at S&S's option if the parts are returned to us by the purchaser within the 12 month warranty period or within 10 days thereafter.

In the event warranty service is required, the original purchaser must call or write S&S immediately with the problem. Some problems can be rectified by a telephone call and need no further course of action.

A part that is suspect of being defective must not be replaced by a Dealer without prior authorization from S&S. If it is deemed necessary for S&S to make an evaluation to determine whether the part was defective, a return authorization number must be obtained from S&S. The parts must be packaged properly so as to not cause further damage and be returned prepaid to S&S with a copy of the original invoice of purchase and a detailed letter outlining the nature of the problem, how the part was used and the circumstances at the time of failure. If after an evaluation has been made by S&S and the part was found to be defective, repair, replacement or refund will be granted.

ADDITIONAL WARRANTY PROVISIONS:

- (1) S&S shall have no obligation in the event an S&S part is modified by any other person or organization.
- (2) S&S shall have no obligation if an S&S part becomes defective in whole or in part as a result of improper installation, improper maintenance, improper use, abnormal operation, or any other misuse or mistreatment of the S&S part.
- (3) S&S shall not be liable for any consequential or incidental damages resulting from the failure of an S&S part, the breach of any warranties, the failure to deliver, delay in delivery, delivery in non-conforming condition, or for any other breach of contract or duty between S&S and a customer.

NOTE: Exhaust Removal is required. Follow factory service manual for proper procedure.

1. Remove screw from brake lever pivot.
2. Remove front brake pedal pushrod screw.
3. Remove brake pedal from brake pedal support bracket.
4. Remove screw that attaches brake pedal pushrod to brake pedal.
5. Remove bolts that attach mid mount bracket to frame.
6. Remove exhaust.
7. Remove ring from brake pivot clevis pin, then remove pin. Remove pivot bolt using 1/2" wrench to hold nut on back side of bell crank. Remove bell crank.
8. Install new S&S bell crank (3) onto frame mounted brake pedal support. Tighten mounting hardware to 100-110 lb./in. Make sure that bell crank can move freely before proceeding to the next step.
9. Insert clevis pin through master cylinder and bell crank, re-attach retaining ring.
10. Install exhaust system.
11. Install standoff (2) into brake lever assembly (1) with low profile screw (6). Make sure to apply thread locker to the threads and tighten to 72 lb./in.



12. Install the toe peg (3) onto brake lever assembly (1) using the flat head cap screw (5). Make sure to apply thread locker to the threads and tighten to 72 lb./in.



13. Install brake pedal pushrod onto brake pedal. Use threadlocker and tighten to 15-18 lb./ft.
14. Using supplied spacers and new provided bolts, reinstall mid mount bracket. Apply threadlocker to bolts and tighten to 35 lb./ft.
15. Install brake pedal on brake pedal support bracket, ensuring that brake pedal can move freely. Tighten brake pedal mounting screw to 100-110 lb./in. using threadlocker.
16. Install front brake pedal pushrod screw into brake lever bell crank. Tighten to 15-18 lb./ft.
17. Check for smooth and complete brake lever travel. Verify proper rear brake operation. Ensure proper clearance between brake pedal and exhaust system.

WARNING
DO NOT RIDE VEHICLE UNTIL BRAKE FUNCTION IS VERIFIED!

18. After riding, periodically inspect brake pedal and linkage for smooth operation and complete brake function.

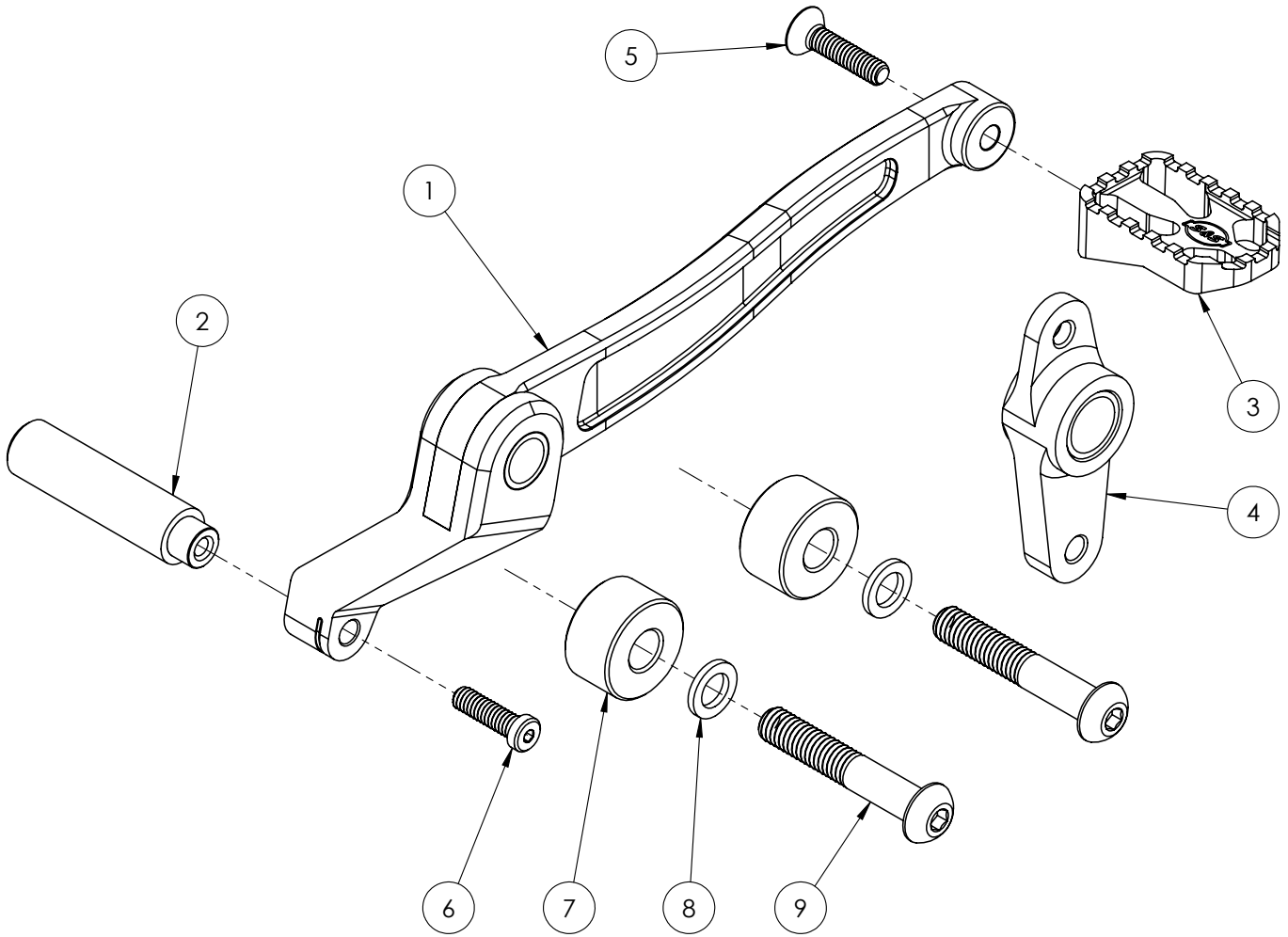

Replacement Parts:

- 1. Lever, Assembly, Brake, Mid Control, Anodized, Black,
Billet, 2018-up M8 Softail" 561-0019
- 2. Standoff, Round, Anodized, .625" OD x .5" OD x 2.62",
Black, Aluminum, 6061 561-0015A
- 3. Peg, Brake, MX Style, S&S" Cycle, Black, 2018-up
M8 Softail" 561-0021
- 4. Bellcrank, Mid Control, Powdercoated, Gloss Black,
2018-up M8 Softail" 561-0012

- Hardware Kit, Brake Lever, Mid Control, Billet, 2018-up M8 Softail" 561-0020
(includes 5-9 below)
- 5. Screw, FHC, Hex, 1/4-20 X 1-1/8", Zinc Plated 500-1779
- 6. Screw, SHC Low Profile, 1/4-20 X 7/8", Zinc Plated 500-1780
- 7. Spacer, Powdercoated, 1-1/8" Od X 7/16" Id X 5/8", Gloss Black 561-0004
- 8. Washer, Flat, 5/8" Od X .390 Id X .078 Thick, 18-8 Stainless Steel 500-1060
- 9. Screw, BHC, 3/8-16 X 2-1/4", Zinc Plated, Alloy Steel 500-1044