



## Installation Instructions: Grand National® 2:2 High for Indian® FTR 1200 — 50-state

### DISCLAIMER:

Many S&S parts are designed for high performance, closed course, racing applications and are intended for the very experienced rider only. The installation of S&S parts may void or adversely affect your factory warranty. In addition such installation and use may violate certain federal, state, and local laws, rules and ordinances as well as other laws when used on motor vehicles used on public highways. Always check federal, state, and local laws before modifying your motorcycle. It is the sole and exclusive responsibility of the user to determine the suitability of the product for his or her use, and the user shall assume all legal, personal injury risk and liability and all other obligations, duties, and risks associated therewith.

Exempt from emissions tampering regulations under CARB EO# K-010-8

### SAFE INSTALLATION AND OPERATION RULES:

Before installing your new S&S part, it is your responsibility to read and follow the installation and maintenance procedures in these instructions and follow the basic rules below for your personal safety.

- Gasoline is extremely flammable and explosive under certain conditions and toxic when breathed. Do not smoke. Perform installation in a well ventilated area away from open flames or sparks.
- If motorcycle has been running, wait until engine and exhaust pipes have cooled down to avoid getting burned before performing any installation steps.
- Before performing any installation steps, disconnect battery to eliminate potential sparks and inadvertent engagement of starter while working on electrical components.
- Read instructions thoroughly and carefully so all procedures are completely understood before performing any installation steps. Contact S&S with any questions you may have if any steps are unclear or any abnormalities occur during installation or operation of motorcycle with an S&S part on it.
- Consult an appropriate service manual for your motorcycle for correct disassembly and reassembly procedures for any parts that need to be removed to facilitate installation.
- Use good judgment when performing installation and operating motorcycle. Good judgment begins with a clear head. Don't let alcohol, drugs or fatigue impair your judgment. Start installation when you are fresh.
- Be sure all federal, state and local laws are obeyed with the installation.
- For optimum performance and safety and to minimize potential damage to carb or other components, use all mounting hardware that is provided and follow all installation instructions.
- Motorcycle exhaust fumes are toxic and poisonous and must not be breathed. Run motorcycle in a well ventilated area where fumes can dissipate.

### IMPORTANT NOTICE:

Statements in this instruction sheet preceded by the following words are of special significance.



#### WARNING

Means there is the possibility of injury to yourself or others.



#### CAUTION

Means there is the possibility of damage to the part or motorcycle.

#### NOTE

*Other information of particular importance has been placed in italic type.*

*S&S recommends you take special notice of these items.*

### WARRANTY:

All S&S parts are guaranteed to the original purchaser to be free of manufacturing defects in materials and workmanship for a period of twelve (12) months from the date of purchase. Merchandise that fails to conform to these conditions will be repaired or replaced at S&S's option if the parts are returned to us by the purchaser within the 12 month warranty period or within 10 days thereafter.

In the event warranty service is required, the original purchaser must call or write S&S immediately with the problem. Some problems can be rectified by a telephone call and need no further course of action.

A part that is suspect of being defective must not be replaced by a Dealer without prior authorization from S&S. If it is deemed necessary for S&S to make an evaluation to determine whether the part was defective, a return authorization number must be obtained from S&S. The parts must be packaged properly so as to not cause further damage and be returned prepaid to S&S with a copy of the original invoice of purchase and a detailed letter outlining the nature of the problem, how the part was used and the circumstances at the time of failure. If after an evaluation has been made by S&S and the part was found to be defective, repair, replacement or refund will be granted.

### ADDITIONAL WARRANTY PROVISIONS:

- (1) S&S shall have no obligation in the event an S&S part is modified by any other person or organization.
- (2) S&S shall have no obligation if an S&S part becomes defective in whole or in part as a result of improper installation, improper maintenance, improper use, abnormal operation, or any other misuse or mistreatment of the S&S part.
- (3) S&S shall not be liable for any consequential or incidental damages resulting from the failure of an S&S part, the breach of any warranties, the failure to deliver, delay in delivery, delivery in non-conforming condition, or for any other breach of contract or duty between S&S and a customer.

**NOTE:** Installation of this system should be done by a qualified mechanic. An overview of stock part removal is presented for guidance, for specific instructions reference the factory service manual for your motorcycle.

1. Remove screw from muffler inlet heat shield and remove heat shield to allow access to muffler clamp. Loosen clamp securing muffler to catalyst chamber outlet. Loosen and remove bolt and nut from muffler mount bracket. Remove Muffler.
2. Loosen clamp securing catalyst chamber to header, remove catalyst chamber mounting hardware. Remove catalyst chamber.
3. Remove heat shields from front and rear header tubes. Loosen clamp securing header assembly to rear head outlet pipe.
4. Locate front header oxygen sensor connector. Unplug oxygen sensor from main wiring harness. Loosen and remove front cylinder head exhaust flange nuts. Remove header.
5. In order to access rear head outlet pipe, it may be necessary to remove the seat, fuel tank and subframe components. Reference your factory service manual for the proper procedure.
6. Locate rear header oxygen sensor connector. Unplug oxygen sensor from main wiring harness. Loosen and remove rear cylinder head exhaust flange nuts. Remove rear head outlet pipe.
7. Remove oxygen sensors from header and head outlet pipe. Install oxygen sensors in S&S front and rear head outlets (7 & 8).
8. Inspect condition of exhaust gaskets, replace if necessary (Indian p/n 5267312).
9. Install S&S front head outlet, install S&S rear head outlet. Tighten exhaust flange nuts to 16 lb./ft.
10. Install rear header pipe onto rear head outlet, install front header pipe onto front head outlet. Leave clamps loose at this time.
11. Install muffler hanger bracket to rear subframe using supplied hardware (17) and tighten to 15-18 lb./ft.
12. Install front muffler (1) onto front header, assemble mounting hardware (13 & 14) through exhaust bracket, leaving bolts loose at this time.
13. Install rear muffler (2) onto front header, assemble mounting hardware (x, x) through exhaust bracket, leaving bolts loose at this time.
14. Align system so that S&S logos on muffler are in perpendicular alignment with the vertical centerline of the motorcycle. Looking at the muffler outlets from the rear of the motorcycle, this is the 3 o'clock orientation. **(See Picture 1).**



**Picture 1**

15. Tighten muffler hardware to 15-18 lb./ft. Tighten header tube to muffler inlet clamp to 35 lb./ft. Finally, tighten header tube to head outlet clamp to 35 lb./ft.
16. Install header and muffler heat shields using two insulating washers (17) per bolt (15). Place washer on bolt, then bolt through heat shield, then second washer on bolt before threading into mounting boss. Install rear header heat shield (5). Leave screws loose at this time. Install front header heat shield (6). Install rear muffler heat shield (4) and front muffler heat shield (3). Align heat shields and tighten screws (15) to 100 lb./in.
17. Reference your factory service manual for the proper procedure to reinstall subframe, fuel tank and seat components that were removed earlier. Verify wiring and fuel connections are correct before attempting to start motorcycle.
18. Thoroughly clean the mufflers with a non-abrasive cleaner before starting the engine.
19. After the first ride allow the bike to cool down and re-check fastener torque.

**NOTE:** While extensive efforts have been made to protect the rider from exhaust system heat, the routing of this race replica exhaust system may expose riders to excessive heat due to circumstances outside of S&S' control. Always wear proper safety gear when riding, avoid long periods of idling or stopped running and avoid direct contact with motorcycle components that may be hot. Failure to follow these precautions may result in severe injury.

## Replacement Parts

1. Muffler Assembly, Top.....	<b>551-1165A</b>	14. Screw, BHC, High Temp Lock Patch, 5/16-18 x 5/8", Stainless Steel.....	<b>500-1091</b>
2. Muffler Assembly, Bottom.....	<b>551-1166A</b>	15. Screw, BHC, High Temp Lock Patch, M6 x 1 x 10mm, Stainless Steel.....	<b>500-1090</b>
3. Heat Shield, Top.....	<b>551-1107</b>	16. Clamp, Band Style, 2.06" - 2.31".....	<b>551-1181</b>
4. Heat Shield, Bottom.....	<b>551-1109</b>	17. Screw, BHC, M8 x 16mm, Stainless Steel.....	<b>500-1189</b>
5. Heat Shield, Rear.....	<b>551-1111</b>		
6. Heat Shield, Front.....	<b>551-1113</b>		
7. Adapter, Front.....	<b>551-1068</b>		
8. Adapter, Rear.....	<b>551-1069</b>		
9. Mounting Bracket.....	<b>551-1114</b>		
10. Header, Front.....	<b>551-1119</b>		
11. Header, Rear.....	<b>551-1122</b>		
12. Gasket, Muffler.....	<b>551-1129</b>		
13. Plate, Nut, 5/16-18 x 2", Clear, Zinc.....	<b>551-0469</b>		

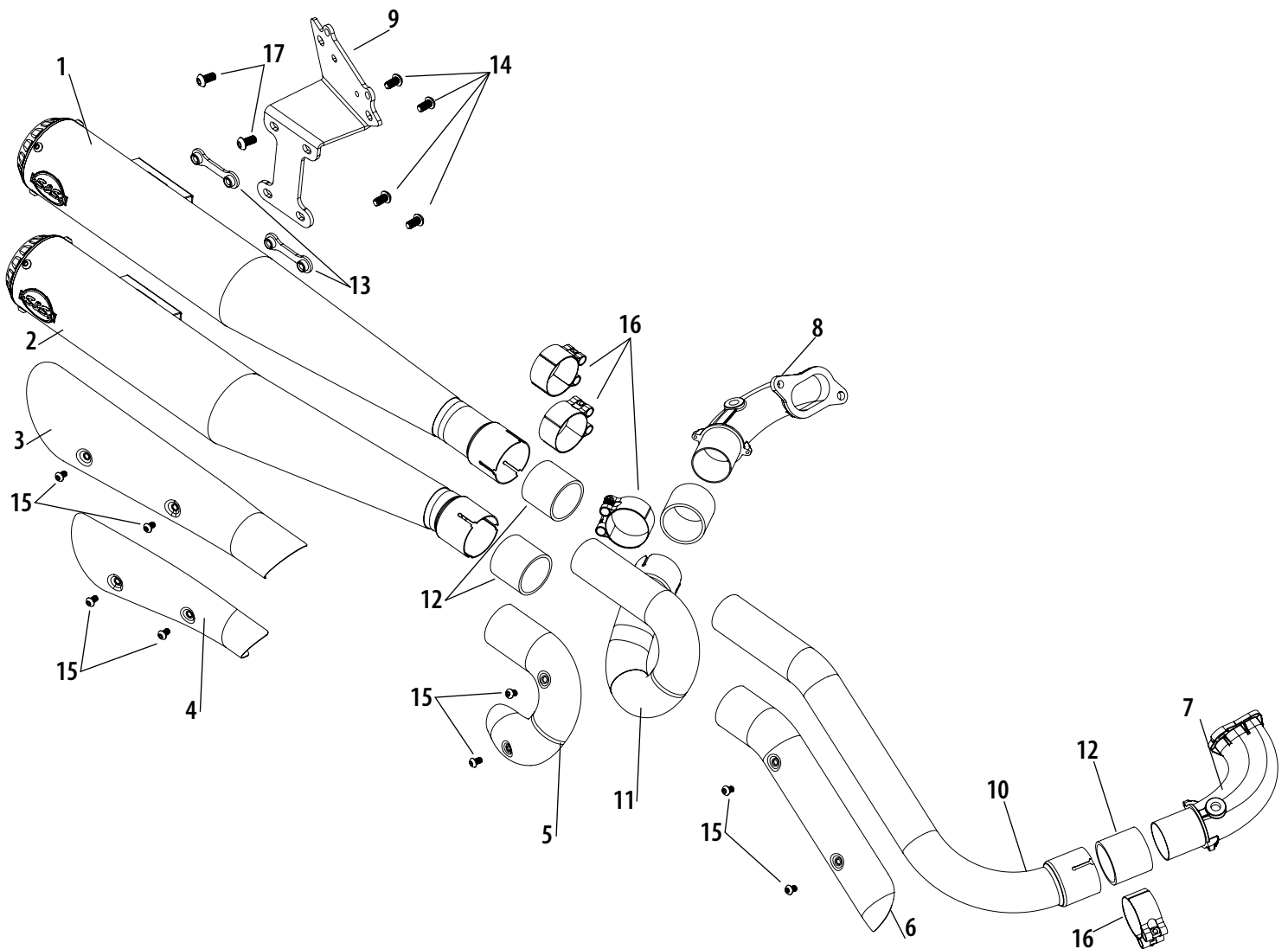

## **EMISSIONS DEFECTS WARRANTY**

The following is an explanation of the emission defects warranty on your new catalyst exhaust system or component. New aftermarket catalyst equipped exhaust components or systems must be designed, built, and equipped to meet stringent emissions standards. S&S must warrant the aftermarket catalyst equipped exhaust components or systems to meet these applicable requirements for the period of time listed below, provided there has been no abuse, neglect, or improper modification of your engine.

### **EMISSIONS DEFECTS WARRANTY COVERAGE**

If this S&S aftermarket catalyst equipped exhaust is installed on a motorcycle within four years of the date that the motorcycle was first acquired by an ultimate purchaser, the emission defects warranty period is five (5) years or 30,000 kilometers (18,641 miles), whichever first occurs.

If this S&S aftermarket catalyst equipped exhaust is installed on a motorcycle more than four years after the date that the motorcycle was first acquired by an ultimate purchaser, the emissions defects warranty period is three (3) years or 15,000 kilometers (9,321 miles), whichever first occurs.

If an emission critical part on your exhaust has been deemed by S&S to be defective, or have damaged an original part of the motorcycle, the part will be repaired or replaced by S&S. This is your EMISSIONS DEFECTS WARRANTY.

### **WHAT IS COVERED BY THIS EMISSION DEFECTS WARRANTY**

The Emission Defects Warranty covers the following "warranted parts" only:

- Original equipment of the exhaust system or component purchased (void if tampered with or not in the original equipment configuration)
- If used on the above: clamps, tubing, sealing gaskets, and mounting hardware.

### **WHAT IS NOT COVERED BY THIS EMISSION DEFECTS WARRANTY**

The following items are not covered by the S&S Cycle, Inc. Emission Defects Warranty:

- Malfunctions in any "warranted parts" caused by any of the following: abuse, misuse, unapproved modification or alteration, tampering, disconnection, or improper maintenance.
- Malfunctions when used with an engine that has been rendered emission non-compliant.
- Discoloration or other cosmetic defects.
- Repairs improperly performed or replacements improperly installed.
- Use in competitive racing or related events.
- Damage resulting from accident, acts of nature, or other events beyond the control of S&S.
- Repairs and services performed by anyone other than an authorized S&S dealer (except in the case of emergency as defined above).
- Loss of time, inconvenience, loss of use of the engine and donor vehicle, towing of the vehicle, or commercial loss and/or consequential damages.

## **OWNER'S WARRANTY RESPONSIBILITIES**

You are responsible for ensuring instructions on the included warranty card are followed and the requested information is returned to S&S. Failure to provide this information could result in a delay of warranty coverage. S&S recommends that you retain all receipts covering purchase and installation of your catalyst equipped exhaust component.

You are responsible for presenting your motorcycle to an S&S dealer as soon as a problem exists. The warranty repairs should be completed in a reasonable amount of time, not to exceed 30 days.

You should be aware that S&S may deny your warranty coverage if a part has failed due to abuse, neglect, or unapproved modifications to the exhaust or engine.

If you have any questions regarding your warranty rights and responsibilities, you should contact S&S Cycle, Inc., 14025 Cty Hwy G, Viola, WI 54664 or the California Air Resources Board, P.O. Box 8001, 9528 Telstar Avenue, El Monte CA, 91734-8001

### **ADDITIONAL WARRANTY TERMS**

The warranty period begins on the date the exhaust is delivered to the ultimate purchaser, or on the date it is first installed.

S&S recommends that you go only to an authorized S&S dealer for repairs under this warranty. He/she has factory-trained mechanics and genuine S&S parts. However, in the case of an "emergency" (as define below), you could have repairs performed at any available service establishment or by the owner. An authorized S&S dealer not being reasonably available, or a part not being available within a reasonable time period (not to exceed 30 days from the time the motorcycle is initially presented to an S&S dealer for repair) constitutes an emergency. S&S will reimburse the owner for such repairs, including diagnosis, only if it is established that the repairs are covered under this emission warranty. S&S's parts reimbursement, however, will not exceed our suggested retail price for all warranted parts replaced and our labor reimbursement will be limited to our recommended time allowances for emission system repairs at the geographically appropriate hourly labor rate. To obtain reimbursement from S&S for such emergency repairs, you must keep all failed parts and original receipts, so you can present them to an authorized S&S dealer for his inspection. S&S recommends that you bring your vehicle to an authorized dealer for inspection to ensure that the emergency repairs were done properly.

The use of non-S&S replacement or approved aftermarket parts does not invalidate the existing warranty, if any, on this or other S&S components unless the non-S&S parts cause damage to warranted parts or result in the creation of an emission non-compliant vehicle. However, S&S ASSUMES NO LIABILITY UNDER THIS WARRANTY WITH RESPECT TO ANY PARTS WHICH ARE NOT GENUINE S&S PARTS, unless genuine S&S parts cause damage to non-genuine S&S parts.