

Instruction 510-1052A  
02.26.2025

**S&S<sup>®</sup> Cycle, Inc.**

14025 Cty Hwy G  
Viola, Wisconsin 54664

Phone: 608-627-1497

Technical Service Email: [sstech@sscyle.com](mailto:sstech@sscyle.com)

Website: [www.sscyle.com](http://www.sscyle.com)



© 2024  
by S&S<sup>®</sup> Cycle, Inc.

All rights reserved.  
Printed in the U.S.A.

## Super Stock Stealth Air Cleaner Kit for Harley-Davidson<sup>®</sup> CVO Touring Models with 121" Engine and 2024-Up Street Glide and Road Glide (PN's: 170-0797, 170-0803)

### DISCLAIMER:

Many S&S parts are designed for high performance, closed course, racing applications and are intended for the very experienced rider only. The installation of S&S parts may void or adversely affect your factory warranty. In addition such installation and use may violate certain federal, state, and local laws, rules and ordinances as well as other laws when used on motor vehicles used on public highways. Always check federal, state, and local laws before modifying your motorcycle. It is the sole and exclusive responsibility of the user to determine the suitability of the product for his or her use, and the user shall assume all legal, personal injury risk and liability and all other obligations, duties, and risks associated therewith. The name "Harley-Davidson<sup>®</sup>" is used in reference only. S&S Cycle is not associated with Harley-Davidson<sup>®</sup> and we in no way are implying that any of S&S Cycle's products are original equipment parts

Exempt from emissions tampering regulations on CVO touring models with M8 121" (1977cc) engine and 2024 Street Glide and Road Glide models under CARB EO# D-355-50

### SAFE INSTALLATION AND OPERATION RULES:

Before installing your new S&S part, it is your responsibility to read and follow the installation and maintenance procedures in these instructions and follow the basic rules below for your personal safety.

- Gasoline is extremely flammable and explosive under certain conditions and toxic when breathed. Do not smoke. Perform installation in a well ventilated area away from open flames or sparks.
- If motorcycle has been running, wait until engine and exhaust pipes have cooled down to avoid getting burned before performing any installation steps.
- Before performing any installation steps, disconnect battery to eliminate potential sparks and inadvertent engagement of starter while working on electrical components.
- Read instructions thoroughly and carefully so all procedures are completely understood before performing any installation steps. Contact S&S with any questions you may have if any steps are unclear or any abnormalities occur during installation or operation of motorcycle with an S&S part on it.
- Consult an appropriate service manual for your motorcycle for correct disassembly and reassembly procedures for any parts that need to be removed to facilitate installation.
- Use good judgment when performing installation and operating motorcycle. Good judgment begins with a clear head. Don't let alcohol, drugs or fatigue impair your judgment. Start installation when you are fresh.
- Be sure all federal, state and local laws are obeyed with the installation.
- For optimum performance and safety and to minimize potential damage to carb or other components, use all mounting hardware that is provided and follow all installation instructions.
- Motorcycle exhaust fumes are toxic and poisonous and must not be breathed. Run motorcycle in a well ventilated area where fumes can dissipate.

### IMPORTANT NOTICE:

Statements in this instruction sheet preceded by the following words are of special significance.



**WARNING**

Means there is the possibility of injury to yourself or others.

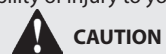

**CAUTION**

Means there is the possibility of damage to the part or motorcycle.

**NOTE**

*Other information of particular importance has been placed in italic type.*

*S&S recommends you take special notice of these items.*

### WARRANTY:

All S&S parts are guaranteed to the original purchaser to be free of manufacturing defects in materials and workmanship for a period of twelve (12) months from the date of purchase. Merchandise that fails to conform to these conditions will be repaired or replaced at S&S's option if the parts are returned to us by the purchaser within the 12 month warranty period or within 10 days thereafter.

In the event warranty service is required, the original purchaser must call or write S&S immediately with the problem. Some problems can be rectified by a telephone call and need no further course of action.

A part that is suspect of being defective must not be replaced by a Dealer without prior authorization from S&S. If it is deemed necessary for S&S to make an evaluation to determine whether the part was defective, a return authorization number must be obtained from S&S. The parts must be packaged properly so as to not cause further damage and be returned prepaid to S&S with a copy of the original invoice of purchase and a detailed letter outlining the nature of the problem, how the part was used and the circumstances at the time of failure. If after an evaluation has been made by S&S and the part was found to be defective, repair, replacement or refund will be granted.

### ADDITIONAL WARRANTY PROVISIONS:

- (1) S&S shall have no obligation in the event an S&S part is modified by any other person or organization.
- (2) S&S shall have no obligation if an S&S part becomes defective in whole or in part as a result of improper installation, improper maintenance, improper use, abnormal operation, or any other misuse or mistreatment of the S&S part.
- (3) S&S shall not be liable for any consequential or incidental damages resulting from the failure of an S&S part, the breach of any warranties, the failure to deliver, delay in delivery, delivery in non-conforming condition, or for any other breach of contract or duty between S&S and a customer.

### Kit Contents - 170-0797:

- Backplate
- Air Filter
- Air Cleaner Cover
- Qty of 3 - 1/4"-20 Backplate Screws
- Qty of 2 - 3/8"-16 Polished Mounting Screws
- Qty of 2 - 1/4"-20 Lava Chrome Air Cleaner Cover Screws
- Qty of 6 - Rubber Coated Washers
- Backplate to Throttle Body O-Ring

### Kit Contents - 170-0803:

- Backplate
- Air Filter
- Top Plate
- Qty of 3 - 1/4"-20 Backplate Screws
- Qty of 3 - 3/8"-16" Polished Mounting Screws
- Qty of 2 - 1/4"-20 Flanged Screws
- Qty of 1 - 5/16"-18 Polished Mounting Screw
- Qty of 6 - Rubber Coated Washers
- Backplate to Throttle Body O-Ring



- **The safety of the motorcycle rider is dependent of proper installation of this product. If you are not certain of your capabilities or do not have the correct tools for this installation, please consult a shop to have it done. Improper installation of this product could result in injury or death to the rider.**
- **Be sure to disconnect the battery of the motorcycle before starting on this procedure. Accidental starting of the motorcycle could cause injury to you or others around you during the installation.**

### Disassembly

#### Stock Air Cleaner Removal

1. Disconnect the negative battery cable from the motorcycle and route it away from any metal parts in the area.
2. Remove the stock air cleaner cover and backplate assembly following your service manual for the specific year and model bike you are working on. Picture 1 shows stock air cleaner removed.

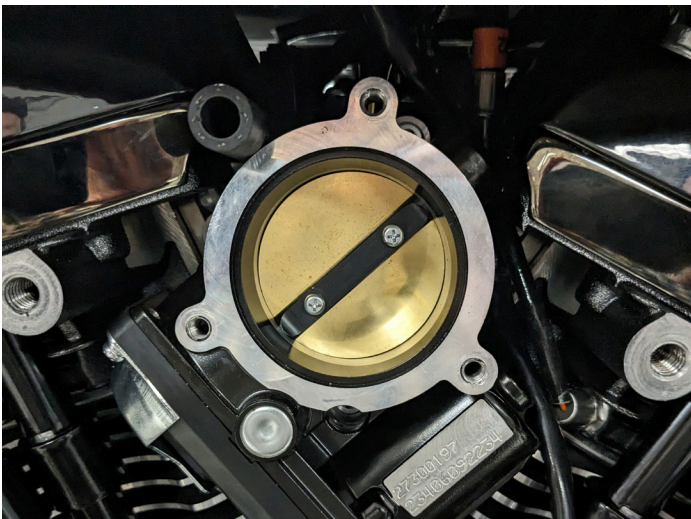

Picture 1

### Installation

#### Installing the S&S Stealth AC Kit

1. Locate the 3, 1/4"-20 screws and o-ring (Picture 2) and install in the back plate as shown in Picture 3. Use a few drops of oil or assembly lube on the o-ring to keep it in place during installation. Apply blue threadlocker to the threads of the 1/4" screws.



Picture 2



Picture 3

- Bring the backplate to the motorcycle and install the beather hose onto the fitting as shown in Picture 5.



**Picture 5**

- Fit the backplate to the throttle body and the cylinder heads. Ensure the O-ring is in place. Start the threads of all the screws and tighten evenly until the backplate is snug.
- Torque the 3 backplate screws to 72 in-lbs.
- Check the fit between the backplate mounting tabs and the cylinder head surface.

**Note:** A feeler gauge works well for determining the amount of gap, if any, between the head and the backplate as illustrated in Picture 6.



**Picture 6**

- If a gap less than the thickness of a rubber coated washer is present, the rubber coated spacer washers are not needed. If a gap of more than the thickness of a rubber coated washer is present, determining how much and select the appropriate number of rubber coated washers needed to make up the gap.

- If no rubber coated washers are needed, apply blue threadlocker to the threads of the Polished Mounting screws, thread into the cylinder heads and torque to 10-12 ft-lbs.
- If one or more rubber coated washers are needed, place the appropriate number of washers between the cylinder head and backplate mounting tabs.
- Apply blue threadlocker to the polished mounting screws, thread into the cylinder heads and torque to 10-12 ft-lbs. It may be necessary to loosen the backplate screws in order to insert the washers. Retorque these fasteners to 72 in-lbs when Step 10 is complete.
- Place the air filter onto the backing plate. See Picture 7.

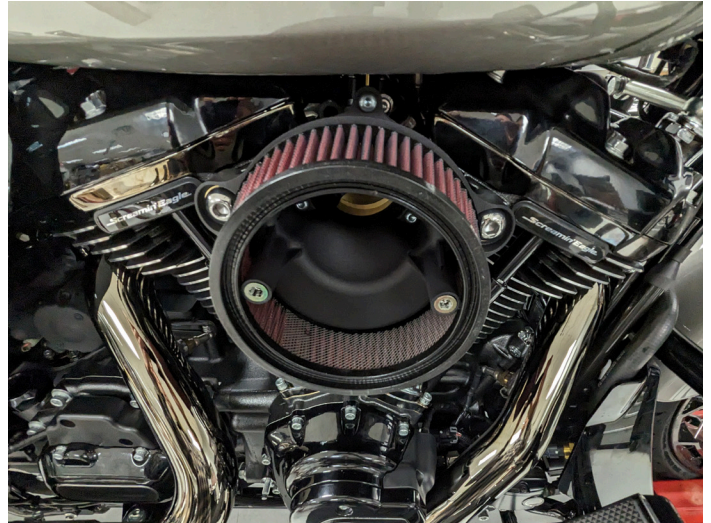

**Picture 7**

- Locate the air cleaner cover and screws. Apply a drop of blue threadlocker to the threads of the screws.
- Place the cover over the air filter making sure the rib on the inside of the cover engage with the slot in the air filter.
- Align the cover/filter assembly with the mounting screw holes in the Stealth back plate. Install the air cleaner cover screws. Tighten screws to 72 in-lb with a torque wrench.
- Apply the included label containing the CARB EO number to the frame down tube above or below the factory label. Do not cover up any portion of the factory label. See **Picture 8**



**Picture 8**

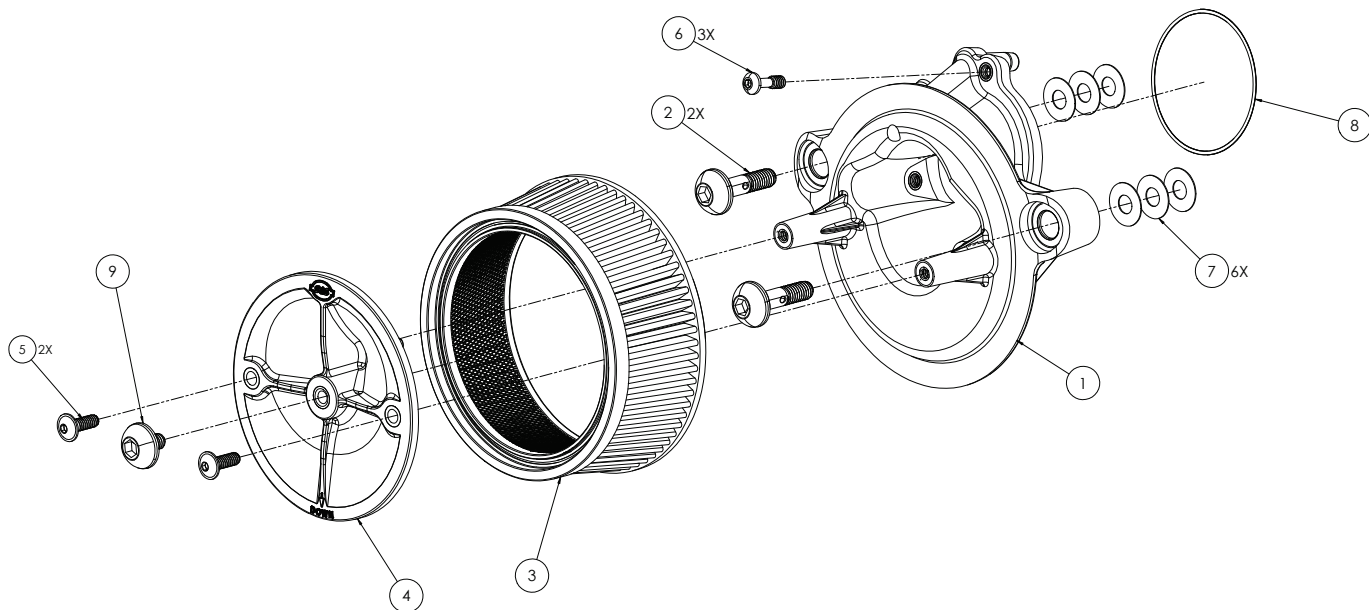

**Kit 170-0803**

- 1. Backplate, Throttle By Wire, W/ 58mm Throttle Body, Stealth, Injection Molded Polymer, 2023-Up M8 ..... 170-0793
- 2. Screw, Backplate Vent, Shcb, 3/8-16 X 1-1/2", Polished, Stainless Steel ..... 170-0506
- 3. Filter, Air, Tapered, Standard Pleated, 5.500" X 6.000" X 2.375", Cotton, Stealth Air Cleaner Kit ..... 170-0043
- 4. Plate, Top, Filter, Air Cleaner, Plastic, Molded ..... 170-0026
- 5. Screw, SHC, Flanged Button, 1/4-20 Unc, .750 In ..... 500-0060
- 6. Screw, SHCB, 1/4-20 UNC X .825" ..... 500-0059
- 7. Washer, Flat, .380" X .880" X .024", Nitrile Rubber Coated, Cold Rolled Steel ..... 50-7054
- 8. O-Ring, (-039), 2.750" Id X 2.875" OD, Nitrile ..... 50-8207-S
- 9. Screw, SHCB, 5/16-18 Unc X .500", Polished, Stainless Steel ..... 170-0508

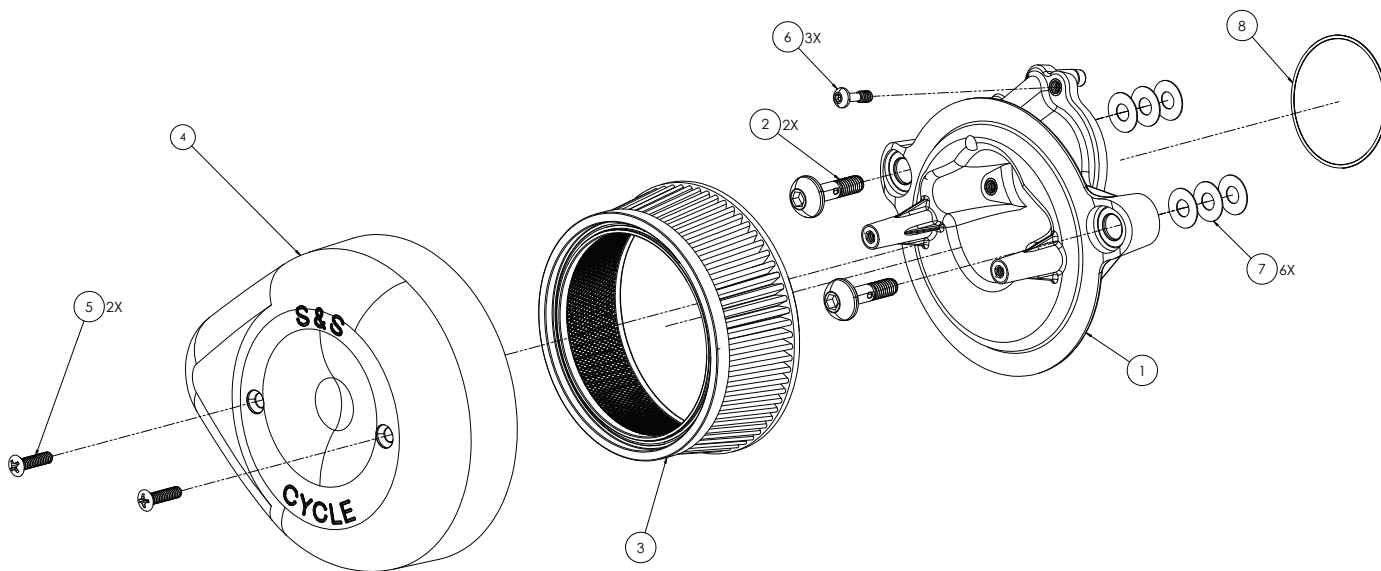

**Kit 170-0797:**

- 1. Backplate, Throttle By Wire, W/ 58mm Throttle Body, Stealth, Injection Molded Polymer, 2023-Up M8 ..... 170-0793
- 2. Screw, Backplate Vent, SHCB, 3/8-16 X 1-1/2", Polished, Stainless Steel ..... 170-0506
- 3. Filter, Air, Tapered, Standard Pleated, 5.500" X 6.000" X 2.375", Cotton, Stealth Air Cleaner Kit ..... 170-0043
- 4. Cover, Air Cleaner, Stealth, Teardrop, Outside Process, Lava Chrome ..... 170-0783
- 5. Screw, Machine, Oval Head, Phillips, Outside Proicess, 1/4-20 X 1", Lava Chrome ..... 500-1775
- 6. Screw, SHCB, 1/4-20 Unc X .825" ..... 500-0059
- 7. Rubber Coated Flat Washer ..... 50-7054
- 8. O-Ring, (-039), 2.750" Id X 2.875" OD, Nitrile ..... 50-8207-S