

ATTENTION

Harley-Davidson® Tri Glide® Owners...
Improve Performance With S&S® Cams and Exhaust!

S&S® Cycle Easy Start

557 CAMS

When choosing a cam for a vehicle like a Tri Glide®, you will be looking for a super torque cam to accelerate the extra weight.

S&S specifically developed the new bolt-in 557 Easy Start cams for the Tri Glide. The short duration produces lots of torque, and the automatic mechanical compression release makes the engine a snap to start! Stock cam base circle allows use of stock pushrods, but we recommend the S&S Quickee pushrods for easy installation. Available in chain drive and gear drive versions. Boost your performance even more with an S&S 3 1/2" round touring muffler and S&S Power Tune Dual header system. Look inside for more information.



Harley-Davidson® Tri Glide® with
S&S® Power Tune Dual header system
and S&S Power-Tour performance
mufflers with chrome billet end cap.
Equipped with 557 Easy Start
cams for easy starting.



V-Twin Performance Since 1958 • **When a legend is not enough**

Order Toll Free 866.244.2673 • www.sscycle.com • Viola, Wisconsin



S&S® 557 CAMS

Fitment

- 2009-'11 Harley-Davidson® Tri Glide® models

Features and Benefits

- Bolt-in – *no headwork*
- Start any engine with a stock starter
- Save your starter and battery!
- Reliable – *tested for 100,000 accumulative starts and over 150,000 road miles without breakage or compression release failure!*
- Automatic – *no buttons to push*



Cam Name	Valve Timing (open/close)		Valve Duration		Valve Lift	Centerline		Lift @ TDC	
	Intake	Exhaust	Intake	Exhaust		Intake	Exhaust	Intake	Exhaust
557	6.0°/26.5°	38.8°/12.4°	212°	231°	0.557"	100°	103°	0.113"	0.146"



Part Numbers

557 Easy Start Chain Drive Cam Kit.....	MSRP \$345.00	330-0053
557 Easy Start Gear Drive Cam Kit	MSRP \$795.00	330-0057
557 Easy Start Gear Drive Cams only	MSRP \$515.75	330-0056



The dyno tells the tale. The lower, black curves show the performance of a totally stock 2009 Tri Glide® as a baseline for comparison. The blue curves show the same trike with S&S Quiet-Tour mufflers, S&S Power Tune dual headers, and an S&S teardrop air cleaner. The top curves, red, show how much more performance can be gained with a set of S&S 557 Easy Start cams. The engine was tuned with the Harley-Davidson® Super Tuner.

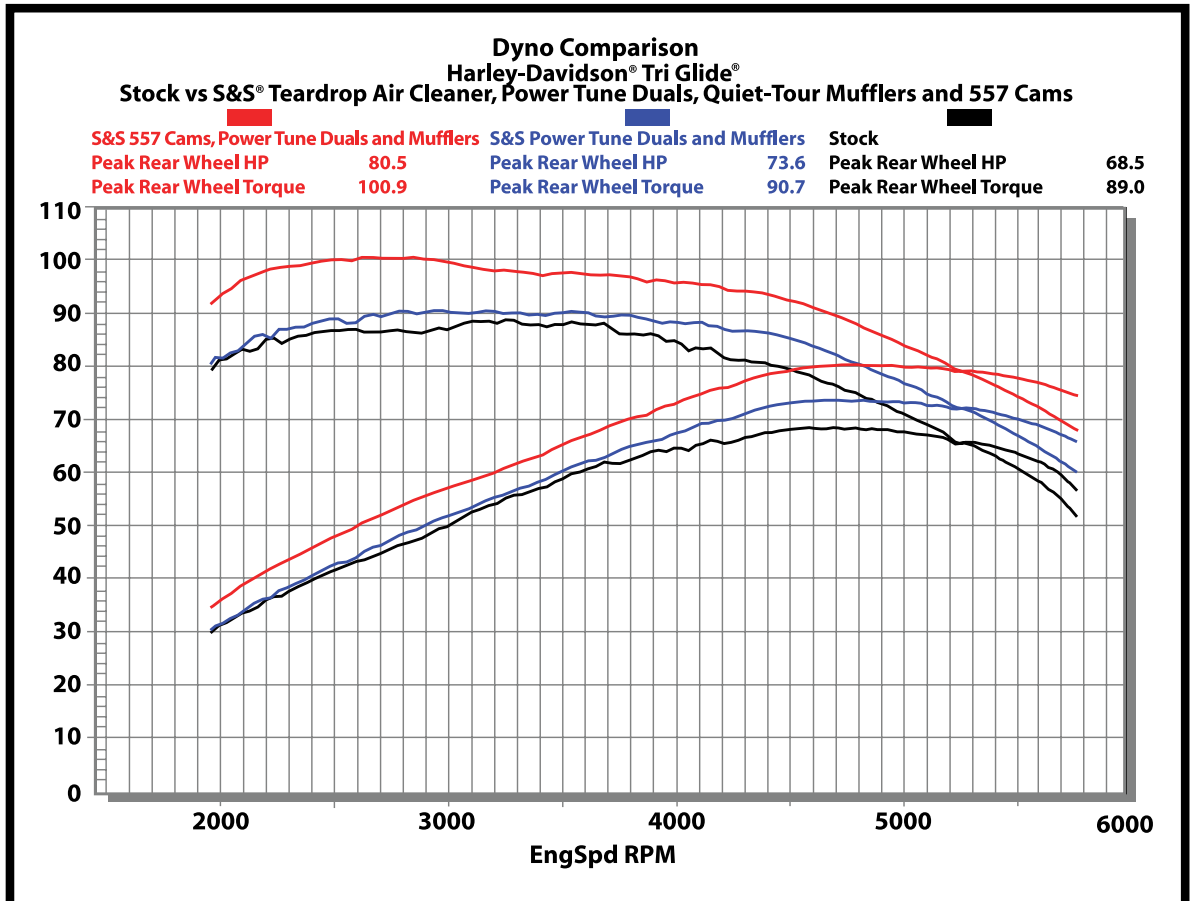

S&S® PUSHRODS

S&S® Cycle Pushrods

QUICKEE PUSHRODS

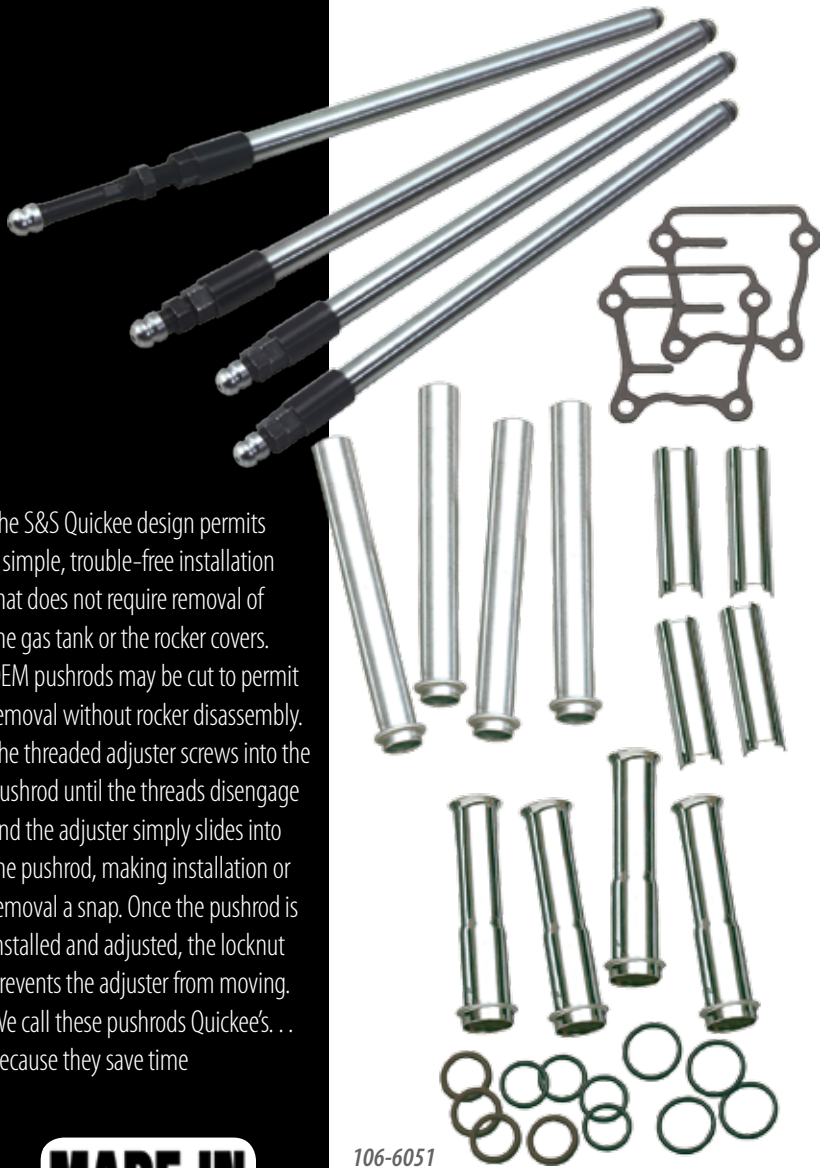

Fitment

2009-'11 Harley-Davidson® Tri Glide® models

Features and Benefits

- Easy to install –removal of rocker box not needed
- Adjustable to accommodate all tappets and cam base circle diameters and engine heights
- Perfect for S&S HL₂T
- No threads on wrench flats

Part Numbers

Quickee Pushrod and Cover Kit.....	MSRP \$285.00	106-6051
Quickee Pushrod Kit Only.....	MSRP \$180.00	93-5122
Special Order Quickee Pushrods.....	MSRP \$225.00	93-5135



When a Quickee is collapsed, it can easily be installed or removed from an assembled engine.

106-6051

S&S® Quickee Pushrod Kit

NOTES:

S&S Quickee pushrods are designed for use with 1984-up hydraulic tappets. They are not compatible with stock or aftermarket hydraulic tappets for shovelhead engines or most solid style tappets.

1984-'99 style pushrod covers are required for access to the Quickee Pushrod adjusters in 1999-up big twins. There is a convenient kit (106-6051) for Harley-Davidson® Twin Cam 88® and Twin Cam 96™ engines that contains the pushrods, tappet cover gaskets, and a set of pushrod covers. That makes it easy to do a Quickee.



S&S® Cycle © #510-0028

V-Twin Performance Since 1958 • **When a legend is not enough**

Order Toll Free 866.244.2673 • www.sscycle.com • Viola, Wisconsin

S&S® EXHAUST

S&S® Cycle Performance Mufflers

POWER-TOUR & QUIET-TOUR

Fitment

2009-'11 Harley-Davidson® Tri Glide® models

Features and Benefits

- Slip-on 3½" round performance muffler
- Chromed all steel mufflers, with slash-down, slash-back, or tapered end
- Chrome muffler with black Xylan® or chrome billet end cap
- Power-Tour version gives you maximum performance
- Quiet-Tour version increases performance with a mellower rumble
- Increased performance with great sound— make even more power with an S&S air cleaner and/or camshaft upgrade
- Bolt-on – economical installation

Part Numbers

Power-Tour Slash-back.....	MSRP \$399.00	106-5982
Power-Tour Slash-down	MSRP \$399.00	106-5981
Power-Tour Billet End Cap Black Xylan®.....	MSRP \$548.00	106-5983
Power-Tour Billet End Cap Chrome	MSRP \$548.00	106-5984
Quiet-Tour Slash-back.....	MSRP \$459.00	106-5977
Quiet-Tour Slash-down	MSRP \$459.00	106-5976
Quiet-Tour Tapered.....	MSRP \$459.00	106-5978
Quiet-Tour Billet End Cap Black Xylan®	MSRP \$580.00	106-5979
Quiet-Tour Billet End Cap Chrome	MSRP \$580.00	106-5980



Xylan® Billet End Cap



Chrome Billet End Cap



Chrome Slash-back



Chrome Slash-down

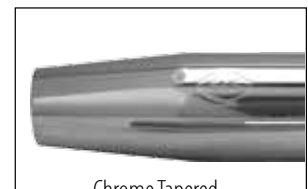

Chrome Tapered

S&S 3½" round mufflers feature a chrome plated steel shell and are double wrapped with both stainless steel wool and basalt wool for long life and durability. Muffler shown with billet end cap with black Xylan® coating.



LISTEN & COMPARE at sscycle.com/audio

SEE MORE AT sscycle.com/performance_exhaust

S&S® EXHAUST

S&S® Cycle Header System

POWER TUNE DUALS

Just like the owners of two wheeled Harley-Davidson® models, Tri Glide® owners are looking for ways to increase performance, and like the two wheel quads, exhaust is usually the first change they make.

This question comes up on our tech line "What exhaust will fit my Tri Glide?" The answer is simple. All of our S&S 3½" round touring mufflers will fit Tri Glide models. To sweeten the deal, our new Power Tune dual headers will also fit Tri Glide models with the addition of some simple pipe extensions, S&S part #550-0088. Unfortunately, due to clearance problems, our SPO® mufflers will not work.



S&S Power Tune Dual header system features an independent dual look with hidden crossover. Full chrome heat shielding with 220° coverage. Mounting hardware included (not shown).

Fitment

- 2009-'11 Harley-Davidson® Tri Glide® models

Features and Benefits

- Adds 8 horsepower over stock header pipes
- Independent dual look with hidden crossover
- Moves the rear cylinder header under the bike to reduce radiated heat to the passenger
- Full chrome heat shielding with 220° coverage
- Updated styling to give the bike a modern look
- Oxygen sensor bungs*
- Durable 16 gauge construction
- Spherical inlet design for improved sealing and exhaust gasket durability
- Hardware included to mount crossover pipe
- Compatible with all slip-on mufflers



550-0088
Pipe Extension Adaptor Kit

Part Numbers

Power Tune Duals*MSRP \$525.00 **550-0004**

* Has both 12mm and 18mm oxygen sensor fittings in the stock locations. Caps are included for both sets of ports.

Pipe Extension Adaptor Kit (required).....MSRP \$79.95 **550-0088**



Power Tune Duals: Fitment on 2010-up model year touring motorcycles is limited to closed course competition use only. All 2010-up touring motorcycles contain a catalyst in the head pipe and removing the catalyst from a highway motorcycle is a violation of pollution control laws.



S&S® INTAKE

S&S® Cycle Intake Systems

TEARDROP AIR CLEANER

Fitment

2009-'11 Harley-Davidson® Tri Glide® models

Features and Benefits

- Uniquely designed back plate has air horn style radiused entryway to reduce turbulence
- Dimpled cover with directional air cone on inside creates smooth path for airflow
- Great addition to performance exhaust or cams

Part Number

Teardrop Air Cleaner MSRP \$219.95 **106-2091**



S&S® Cycle Intake Systems

TUNED INDUCTION SYSTEM

Fitment

2009-'11 Harley-Davidson® Tri Glide® models

Features and Benefits

- Bolt-on performance
- Large increase in filtering area over stock air cleaner
- Smooth intake tract of carefully selected tuned lengths increases performance
- High flow washable and reusable cotton media provides performance, protection, and economy

Part Numbers

Tuned Induction System (Chrome) MSRP \$462.47 **106-2448**

Tuned Induction System (Black) MSRP \$396.55 **106-2447**



One of the most recognizable shapes in the industry! Genuine S&S teardrop air cleaners have a uniquely designed backplate with air horn style radiused entryway and dimpled cover with air directional cone on the inside. This design helps maximize airflow by giving intake air an efficient path to follow into the carburetor or throttle body.



Offering over twice the filtering area of stock intake systems, the tuned runner increases horsepower and torque across the rpm range using air column inertia and carefully timed gas dynamic pressure waves.

SPECIAL NOTES:

Does not fit Screamin' Eagle 58mm throttle bodies on 2008-up touring models.

Tuned induction will not fit on motorcycles equipped with fairing lower glove boxes.

