

Instruction 51-1011
4-27-06

Copyright© 1991, 1999, 2006
by S&S Cycle, Inc.
All rights reserved.
Printed in the U.S.A.

S&S® Cycle, Inc.

235 Causeway Blvd
La Crosse, Wisconsin 54603

Phone: 608-627-1497 • Fax: 608-627-1488
Technical Service Phone: 608-627-TECH (8324)
Technical Service Email: sstech@sscycle.com
Website: www.sscycle.com



Installation Instructions: Super E & G Air Cleaner Backplate Assembly

Super E and Super G air cleaner backplates, parts #17-0330, #17-0336 and #17-0380, come disassembled and must be assembled before installation. The line drawing below shows the correct sequence of assembly of the fast idle lever mechanism. Tighten fast idle screws, part #50-0041, securely without stripping threads in backplate. Loctite® or some other "thread glue" may be used sparingly on screw threads to be sure they do not vibrate loose.

1. Washer, fast idle frictionPart #50-7035
2. Washer, fast idle steelPart #50-7037
3. Washer, fast idle nylonPart #50-7036
4. Lever, fast idle:
All except '91-up Harley-Davidson®
Sportster® modelsPart #17-0329
'91 Sportster® modelsPart #17-0327
5. Washer, fast idle brassPart #50-7007
6. Screw, fast idle leverPart #50-0041
7. Backplate, air cleaner
'55-'84 bt, '57-'85
Sportster® modelsPart #17-0330
'84-'92 bt, '86-'90
Sportster® modelsPart #17-0380
'93-up bt, '91-up
Sportster® modelsPart #17-0336

Notes:

- Part #50-7035 (bowed spring washer) - Place radiused side towards backplate.
- Part #50-7007 - Place stepped side towards backplate.
- Part #50-0041 - Tighten securely without stripping threads in backplate.

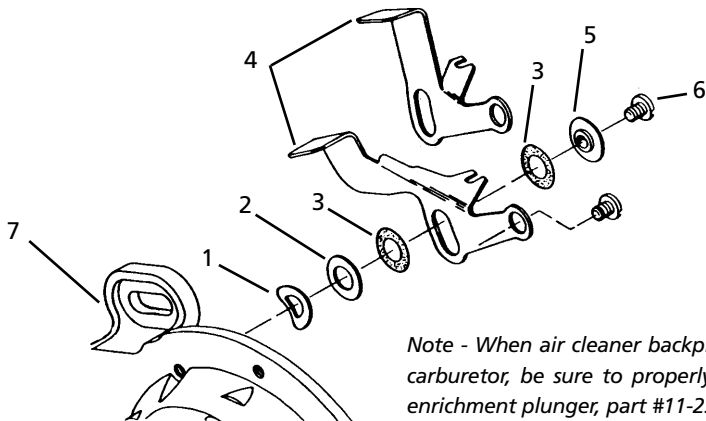

Note - When air cleaner backplate is installed on carburetor, be sure to properly engage fast idle enrichment plunger, part #11-2343

Instruction 51-1011
4-27-06

Copyright© 1991, 1999, 2006
by S&S Cycle, Inc.
All rights reserved.
Printed in the U.S.A.

S&S® Cycle, Inc.

235 Causeway Blvd
La Crosse, Wisconsin 54603

Phone: 608-627-1497 • Fax: 608-627-1488
Technical Service Phone: 608-627-TECH (8324)
Technical Service Email: sstech@sscycle.com
Website: www.sscycle.com



Installation Instructions: Super E & G Air Cleaner Backplate Assembly

Super E and Super G air cleaner backplates, parts #17-0330, #17-0336 and #17-0380, come disassembled and must be assembled before installation. The line drawing below shows the correct sequence of assembly of the fast idle lever mechanism. Tighten fast idle screws, part #50-0041, securely without stripping threads in backplate. Loctite® or some other "thread glue" may be used sparingly on screw threads to be sure they do not vibrate loose.

1. Washer, fast idle frictionPart #50-7035
2. Washer, fast idle steelPart #50-7037
3. Washer, fast idle nylonPart #50-7036
4. Lever, fast idle:
All except '91-up Harley-Davidson®
Sportster® modelsPart #17-0329
'91 Sportster® modelsPart #17-0327
5. Washer, fast idle brassPart #50-7007
6. Screw, fast idle leverPart #50-0041
7. Backplate, air cleaner
'55-'84 bt, '57-'85
Sportster® modelsPart #17-0330
'84-'92 bt, '86-'90
Sportster® modelsPart #17-0380
'93-up bt, '91-up
Sportster® modelsPart #17-0336

Notes:

- Part #50-7035 (bowed spring washer) - Place radiused side towards backplate.
- Part #50-7007 - Place stepped side towards backplate.
- Part #50-0041 - Tighten securely without stripping threads in backplate.

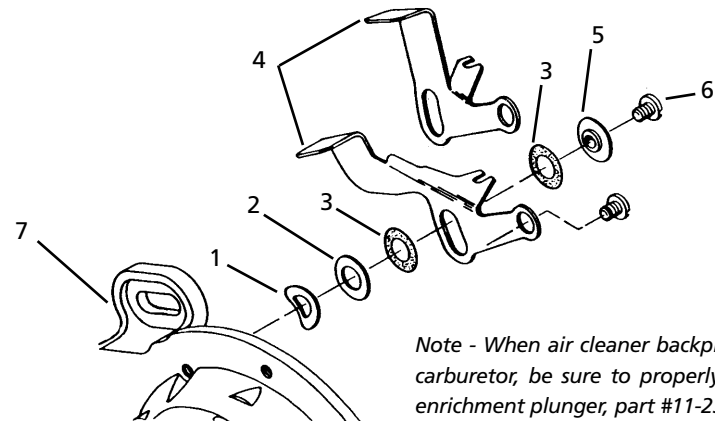

Note - When air cleaner backplate is installed on carburetor, be sure to properly engage fast idle enrichment plunger, part #11-2343